

OUTFEED ROLLERS™

Operators Manual

FOR MODELS:

HOR-1026U

HOR-1038U



OUTFEED ROLLERS™

Thank You and Congratulations!

Thank you for your recent purchase of HTC Outfeed Rollers. This product is manufactured by craftsmen dedicated to making high quality, reliable products. All HTC products are backed by our Limited Lifetime Warranty* and a responsive, dedicated customer service department. We would appreciate hearing your comments or suggestions. Please feel free to call or write anytime. We welcome correspondence from everyone who has ever purchased or used one of our fine products.

A Word About Your New Outfeed Rollers

A unique patented HTC exclusive! A work support that's always in place and ready to use. Outfeed Rollers support the workpiece to 4' past the blade. That's a full 48" to help balance a full 8' panel. HTC Outfeed Rollers are compatible with most fence systems on the market and have a patented cam action adjustment that lowers the Outfeed Rollers 3/8" for proper support of sliding cross-cut and miter slot fixtures. Folds down easily for compact storage and swings into place without the use of tools. When you work with full 4' x 8' panels and extra long boards, HTC Outfeed Rollers let you rip and cross-cut easily, accurately... but most importantly safer by yourself.

General Product Safety Warning

As with all products there are certain hazards involved with their operation and use. Using any product with respect, caution, and common sense will considerably lessen the possibility of personal injury. Safety is a combination of staying alert, knowing how the product works, and knowing how to properly use the product. To use any product safely you should plan ahead and practice the proper steps prior to actually using the product. If safety rules and instructions are overlooked or ignored, personal injury to the operator or other people in the area may result. Safe operation of any product requires that you read and understand the product instructions and all labels affixed to the product.

Always read and follow all instructions and safety rules carefully.

This product is designed for certain uses only. This product or any of its parts shall NOT be altered, changed, or modified in any way and/or used for any other use than it's designed for. If you have any questions about its proper care or use DO NOT use the product until you have written HTC and we have advised you in writing.

HTC Products, Inc.
332 E. Lincoln Ave.
Royal Oak, MI 48067
248-399-6185 • 800-624-2027
www.htcproductsinc.com

8:00 AM to 5:00 PM EST/EDT Monday – Friday

* See back cover for complete Warranty information.

General Safety Rules

The following general safety rules are supplied as an aid for the safe use of many products. This is NOT a complete list of all possible safety rules. Safe use of a product includes but should NOT be limited to the following safety rules.

1. **For your own safety, read instruction manual before operating the tool. Know the tool.** Read and understand the owner's manual and labels affixed to the tool.
2. **Keep work area clean.** Cluttered areas and benches invite accidents and create fire hazards.
3. **Wear proper apparel.** Do not wear loose clothing, gloves, neckties, bracelets, drawstrings, necklaces, ornaments, rings, wristwatches, or jewelry of any kind. They can get caught and pull you into moving parts.
4. **Avoid dangerous environment.** Keep alert to potential hazards in the working environment. Do not use tool in situations such as damp or wet locations or in the presence of highly combustible materials, dust, and flammable liquids, fumes, vapors or gasses.
5. **Keep children and visitors away.** All visitors should be kept a safe distance from work area.
6. **Wear safety goggles.** Wear safety goggles (not glasses) at all times. All eye protection must comply with the ANSI Z87.1 standard for eye protection. Everyday eyeglasses only have impact resistant lenses, they are NOT safety glasses.
7. **Drugs, alcohol, medication.** Stay alert. Watch what you are doing. Use common sense. Do not operate tool when you are tired, upset, ill, or while under the influence of drugs, alcohol, or medication.
8. **First aid.** Have at least one person with first aid training and first aid kits approved by American National Red Cross available at all times.
9. **Fire extinguisher.** Familiarize yourself in the use of portable fire extinguishers. Post the telephone number of the local fire department. Also develop and know emergency procedures in case of fire.
10. **Smoke Detector.** To increase protection against fire, install smoke detectors. For proper selection and installation guidelines contact your local fire department.
11. **Use right tool.** Don't force tool or attachment to do a job it was not designed for. Don't use tool for purpose not intended – for example – do not use circular saw for cutting tree limbs or logs or do not use a lawnmower to trim bushes or hedges.
12. **Don't force tool.** It will do the job better and safer at the rate for which it was designed.
13. **Secure work.** Keep hands well away from moving parts, saw blades, and other cutting tools. Use a push stick or push block to hold or guide the work when working close to cutting tool. Use jigs, fixtures, miter gauge, clamps or vises to hold work when practical. Use a featherboard when an applicable guard cannot be used or for added safety. Loose workpieces are a hazard.
14. **Never leave tool running unattended.** Turn power off. Don't leave tool until it comes to a complete stop.

Table of Contents

Safety Rules	3-4
LVC Box Relocation	5-6
Components/Hardware	7
Installation	8-10
Operating Tips	11
Warranty Information	12

15. **Keep guards in place.** Be sure that guards, hold-downs, and antikickback devices are in working order, and positioned properly, and are in proper adjustment and alignment.
16. **Remove adjusting keys and wrenches.** Form the habit of checking to see that keys and adjusting wrenches are removed from the tool before turning the tool on.
17. **Cutting tool exposure.** Adjust the tool for minimum exposure of cutting tool necessary to perform the operation.
18. **Direction of feed.** Feed work into a blade or cutting tool against the direction of rotation of the blade or cutting tool only.
19. **Don't overreach.** Keep proper footing and balance at all times.
20. **Never stand on tool.** Serious injury could occur if the tool is tipped or if the cutting tool is accidentally contacted.
21. **Avoid accidental starting.** Make sure switch is in the "OFF" position before plugging in tool. Do not carry a plugged in tool with finger on switch.
22. **Inspect workpiece.** Always inspect workpiece to make sure there aren't any nails or foreign objects in the part of the workpiece to be worked on.
23. **Plan ahead.** Mentally plan ahead to protect your eyes, hands, body, face and hearing. Do layout, assembly, setup work, material handling, and planning before using tool.
24. **Disconnect tools.** Always turn tool "OFF" and disconnect the cord from the power source before tool is serviced or when installing or removing accessories such as blades, bits, or cutters etc.
25. **Maintain tools with care.** Inspect tool before each use. It is recommended that the general condition of any tool be examined before it is used.
26. **Check damaged parts.** Before further use of the tool, a guard or other part that is damaged should be carefully checked to ensure that it will operate properly and perform its intended function.
27. **Ground all tools.** Make sure wiring codes and recommended electrical connections are followed and that tool is properly grounded.
28. **Outdoor use extension cords.** When tool is used outdoors, use only extension cords marked "suitable for use with outdoor appliances – store indoors when not in use."
29. **Ground Fault Circuit Interrupters - (GFCI's)** provide additional means to reduce serious electrical shock while using a power tool. They are easily installed between the power receptacle and the cord. Leakage of current will shut off the tool, preventing possible serious injury from electrocution.

Attention Delta Unisaw Owners

If your table saw is a Delta Unisaw, with an LVC (Low Voltage Controller) box mounted on the rear of the table saw cabinet, please read and follow the instructions in this section carefully before proceeding with installation of the HTC Outfeed Roller System. Otherwise skip to next page.

The LVC box may need to be lowered 3" to provide enough space for the top mounting channel of the Outfeed Roller Main Frame. Read through the entire installation instructions prior to moving your LVC box. The following instructions will guide you step by step through the simple procedure of lowering the LVC box, if necessary.

Tools needed to lower the Delta Unisaw LVC Box

- Safety goggles
- Hand drill with 1/8" and 11/32" drill bits
- Scribe, awl or marking device
- File or deburring tool to remove sharp edge from holes
- Center punch
- Ball peen hammer
- 1-1/2" diameter hole saw (available at any hardware store)
- Two (2) 1/2" wrenches

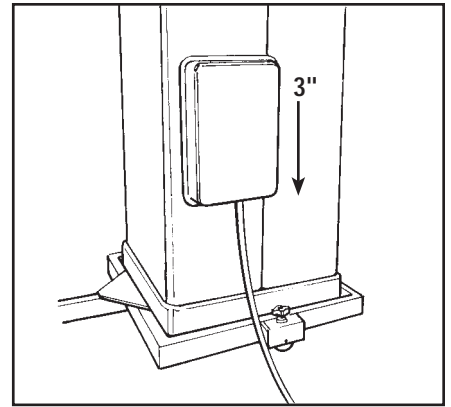

LVC box may need to be lowered 3"

Lowering the Delta Unisaw LVC Box

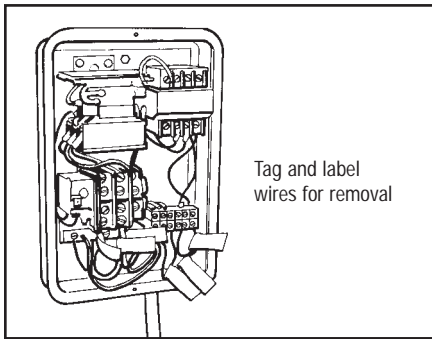

LVC Box

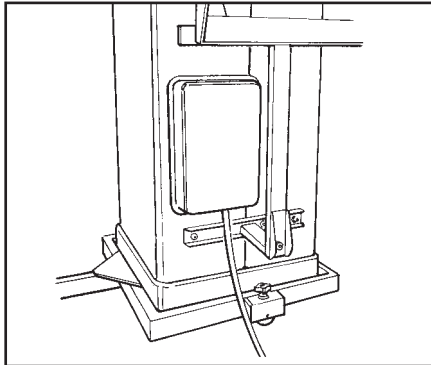

Relocated LVC box with main frame

WARNING: To avoid electrocution disconnect power from the table saw before proceeding.

1. Remove the cover of the LVC box. Tag and disconnect the six (6) wires from the terminals.
2. Remove locknuts from the two (2) wire clamps and pull the wires through the back of the LVC box.
3. Disconnect LVC box by removing three (3) 5/16" bolts and nuts.
4. Locate top two (2) existing mounting holes. Relocate these same holes 3" lower than old holes. Mark with center punch. Drill 1/8" pilot holes to reduce wander in sheet metal. Drill the two new 11/32" holes. Remove sharp edge on holes.
5. Temporarily remount LVC box with the two (2) top mounting bolts in the new 3" lower holes. Trace the outline of the lower mounting hole and the two (2) wire access holes.
6. Remove the LVC box again. Mark and center punch the three (3) holes traced in Step 5.
7. Drill three (3) 1/8" pilot holes. Drill 11/32" lower mounting hole. Drill two (2) wire access holes with 1-1/2" diameter hole saw. Remove sharp edge on holes.
8. Remount the LVC box, rewire making sure to match tagged wires from Step 1 and replace cover.



OUTFEED ROLLERS™

MAIN FRAME MOUNTING TEMPLATE

FOR MODELS HOR-1026U HOR-1038U

BASE LINE

CENTER LINE

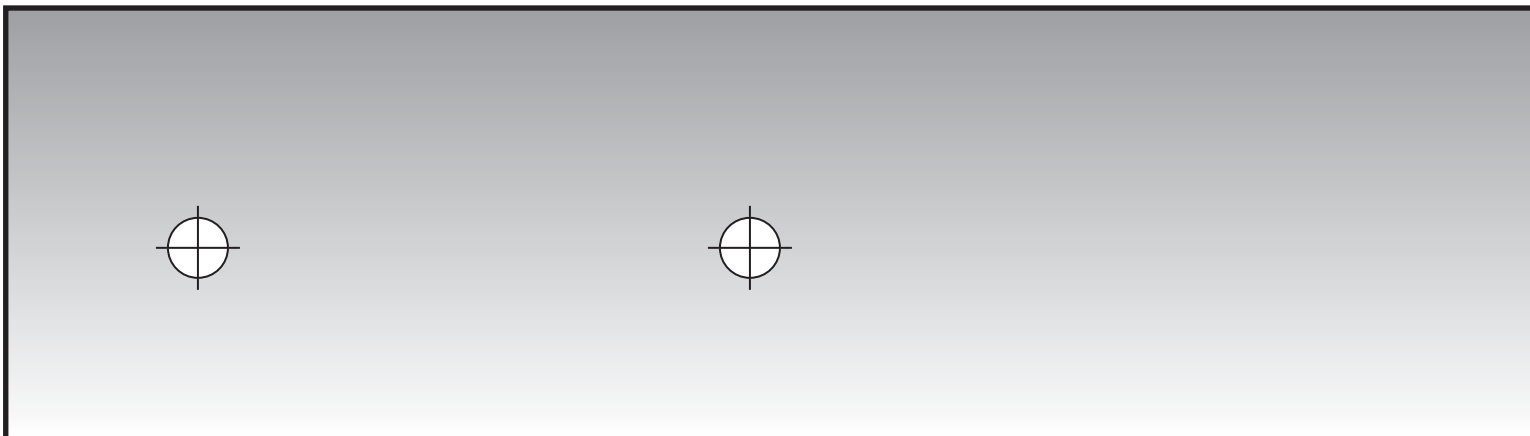

CENTER PUNCH 4 POINTS ABOVE, AND DRILL PILOT HOLE WITH 1/8" DRILL.

Unpacking and Checking Contents

Separate all parts and hardware from packing materials. Check each part with the table and hardware chart to make sure all items are accounted for and are in good condition. Do not discard packaging materials until assembly is completed and you are satisfied with the product.

Key	Size	Name	Qty	Part No.
A	5/16" - 18 x 1"	Hex Bolt	6	C206
B	5/16" - 18 x 1"	Carriage Bolt	4	C306
C	5/16" - 18	Hex Nut	10	C202
D	5/16"	Flat Washer	12	C204
E	5/16"	Lock Washer	12	C208
F	5/16" - 18 x 1/2"	Knob - 3 Point	2	G101
G	3/8" - 16	Acorn Nut	4	C408
H	3/8" ø	Pivot Rod	2	2272
J		Pivot Pins	2	2036
K		Cam Bolt	2	2343
L		Stud Pad	2	2887
M		Cam	2	2106
N		Plate, Table Adjustment	1	3089
P		Support Arm, Folding	1	5094

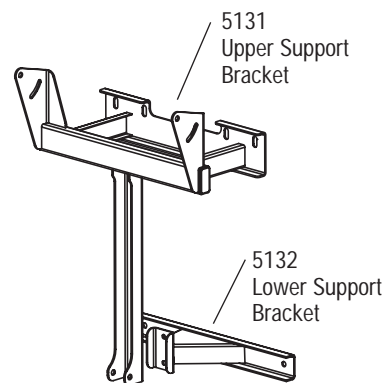

5100 = 5131 + 5132

WARNING:
Do not attempt to use the product if parts are missing. Contact factory at 800-624-2027 to obtain the necessary parts.

Model No.	Main Frame	Roller Frame		Rollers		
		5007A	5061A	9.5"	10"	13"
HOR-1026U	X		X	1	4	5
HOR-1038U	X	X		2	8	5

TAPE THIS TEMPLATE TO MACHINE CABINET WITH "BASE LINE" EXACTLY 3 1/2" BELOW FINISHED SURFACE OF MACHINE TABLE AND "CENTER LINE" ON CENTER OF MACHINE

SET BASELINE AT 3 1/2" BELOW TOP FINISHED SURFACE OF MACHINE TABLE



BASE LINE

CENTER LINE

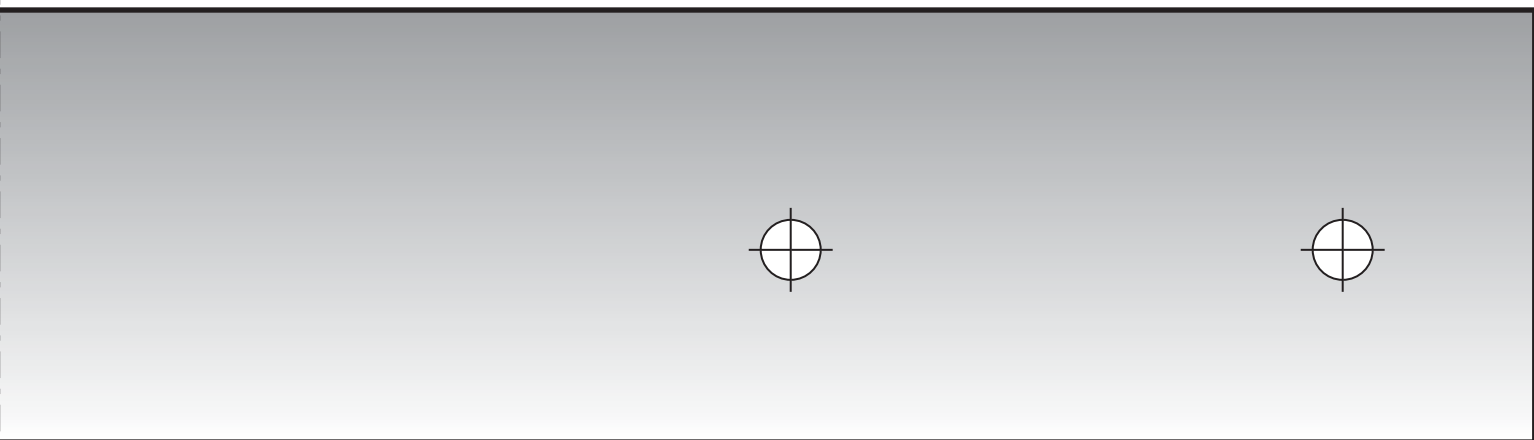

THEN ENLARGE WITH 1 1/32" DRILL FOR 5/16" MOUNTING BOLTS.



Figure 1

Installation Instructions

Tools needed for Assembly

- Safety goggles
- Scribe, awl or marking device for marking on sheet metal
- Center punch
- Ball peen hammer
- File or deburring tool to remove sharp edge from holes
- Combination square
- Framing square or long straight edge
- Hand drill with 1/8" and 11/32" drill bits
- 1/2" deep socket wrench
- 1/2" open end wrench
- 7/16" socket wrench and/or open end wrench

Note: Read through **ALL** installation instructions and review all diagrams before attempting installation.

WARNING: To avoid electrocution disconnect power from the table saw before proceeding.

READ THROUGH ENTIRE INSTALLATION INSTRUCTIONS BEFORE PROCEEDING

1. Position and mount with tape the enclosed Main Frame Mounting Template to the rear of Table Saw, as shown in Figure 1. Set the Base Line (on the template) 3 1/2" below the table top surface of the table saw.

Important: Base Line must be parallel with the table top or Outfeed Roller unit will not work properly.

2. Using a center punch, mark the four (4) mounting holes on the Template. Drill 1/8" pilot holes to reduce bit wander in sheet metal. Then enlarge holes by drilling with 11/32" drill to accommodate 5/16" mounting bolts. Step drills work especially good in sheet metal.
3. Mount the Main Frame **(1)** to the saw cabinet using two (2) stud pads **(2)**, along with (2) 5/16"-18 x 1" bolts, (2) 5/16" - 18 nuts **(3)**, (4) 5/16" flat washers **(4)** and (4) 5/16" lock washers **(5)**. (Hand tighten only.)

Tip: When installing the stud pads and Main Frame on some machine models, you'll need to "hang" the stud through one of the holes, then rotate the stud pad into position and thread the bolt into place. Usually the back of the saw cabinet can be reached from the opening on the side of the saw. On the rare occasions it's necessary to lay the saw on its side and feed them in from the bottom. Figure 2.

4. Assemble the Lower Main Frame Bracket to the Main Frame. Mount as low as is practically possible, for best results. It can be flipped over if needed. The point is to avoid any interferences on the cabinet.

Important: Do Not Drill the lower holes in the cabinet at this time.

5. Attach the Cams **(6)** to the Main Frame using Cam Bolts **(7)** and Knobs **(8)** as shown in Figures 3 & 4.
6. Install (1) one of the Pivot Bolts **(9)** into one of the Cams, as shown in Figures 4 & 5. Then slip the Roller Frame onto this Pivot Bolt. Swing the Frame into position between the Cams and thread the other Pivot Bolt into place. Refer to photos to get the correct orientation.
7. Attach the Adjustment Plate **(10)** to the underside of the Roller Frame as shown in Figure 11 using (4) four 5/16" Carriage Bolts **(11)**, washers, lock washers and nuts. Use care to orient the Adjustment Bolt to the 'front' as shown.
8. Pivot Roller Frame out of your way. It can flip over onto the top of the saw. Attach the Support Arm Assembly **(12)**, as shown in Figure 6, to the bottom of the Main Frame with a Pivot Rod **(13)** and (2) two Acorn Nuts.

Note: It is very important to mount the correct end of the Support Arm Assembly.

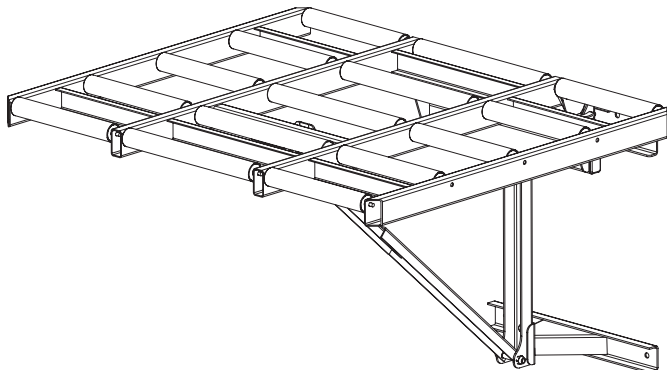

Figure 2



Figure 3

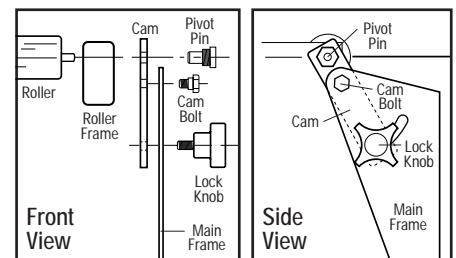

Figure 4



Figure 5



Figure 6



Figure 7

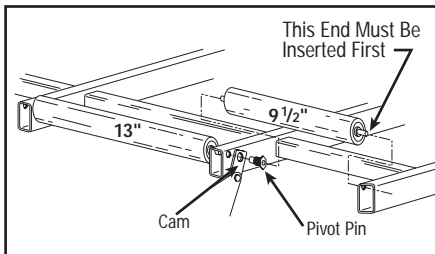

Figure 8



Figure 9



Figure 10

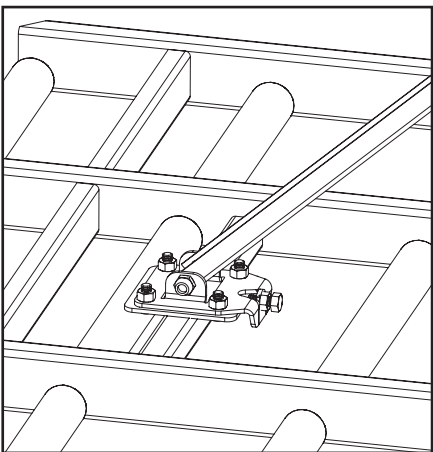
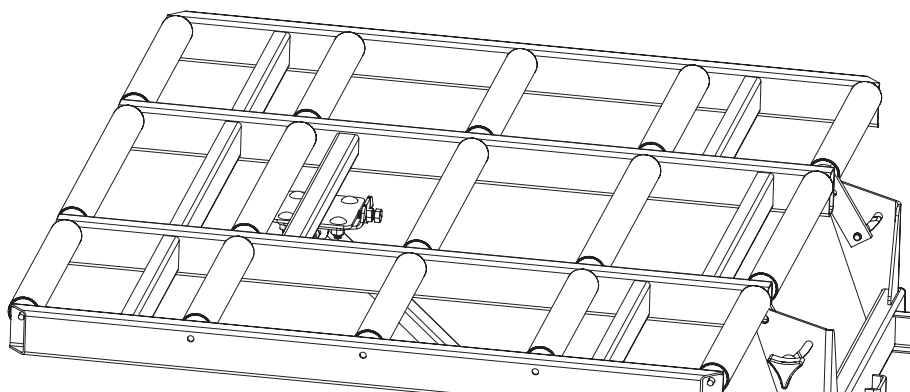

Figure 11

9. Pivot the Roller Frame back over and attach the upper end of the Support Arm to the Adjustment Plate **(N)** using a Pivot Rod **(H)** and (2) two Acorn Nuts **(G)**.
10. Insert (2) 9 1/2" Rollers into Roller Frame as shown in Figure 7 & 8. Use thin putty knife (or something similar) to compress the spring loaded axle.
Note: It is very important to install the rollers with fixed end in outside frame. You are now ready to make the final adjustments to your Outfeed Roller.
11. Lay a straight edge on saw table top extending out to first roller closest to saw table (Figure 9). Adjust position of Main Frame to bring both ends of rollers level with saw table top. Table remains folded down — cams positioned as in Figure 3 & 4. Tighten top Main Frame nuts and bolts.
12. Swing roller section into it's extended position. Tighten or loosen Adjustment Bolt to bring outboard rollers level and parallel with saw table top. Tighten the top leveling bracket mounting bolts Figures 10 & 11.
13. Double check and make sure Roller Section is mounted level with the saw table top (side to side). Then mark and drill lower mounting holes. Install (2) 5/16" - 18 x 1" bolts with flat washers through the outside of the saw cabinet, with flat washers **(D)**, lock washers **(E)**, and 5/16" - 18 nuts **(C)** on the inside. Tighten securely.
Note: Before drilling the lower mounting holes on some saw models you may find the angled dust pan within the cabinet becomes an obstruction to proper installation. You may want to adjust the position of Lower Main Frame Bracket.
14. Measure the approximate distance between the mounting holes on the Main Frame Bracket.
15. From the inside of the cabin, using the measurement from Step 14, measure from the top holes down to determine the approximate location of lower mounting holes. They may fall above the dust pan, below the pan or straddle the pan.
16. If the approximate location of the holes fall above the pan, proceed with normal installation. If the mounting bolts will fall below the dust pan, proceed to the next step.
17. If the dust pan is mounted to the cabinet using screws and the stud falls below the pan, the pan can be removed to complete the installation.
18. If the dust pan is welded in and the holes will fall below the dust pan, the bolts can be installed from the bottom, by tipping of blocking the saw up. Use extreme caution when working on the saw from the bottom.
19. Position Cam **(M)** so Roller Frame is in the lower position. Make sure miter gauge guide bar rests level on first roller.

Re-check and tighten all fasteners.



Outfeed Roller Feature and Operating Instructions

Cam Action

The unique cam-action of the HTC Outfeed Rollers allow the roller surface to be quickly and easily lowered 3/8" to support the miter gauge bar. This allows the use of miter or cross-cut boxes or any other sliding miter fixtures or jigs. The cam-action assures that the rollers remain parallel to the table saw and that the fully adjustable height mechanism remains in precise alignment with the table saw surface and miter gauge slot.

Figure 12 shows the cam-action in the down position with the rollers in the up position for supporting the workpiece in a normal cutting mode.

Figure 13 shows the cam-action in the up position with the rollers in the down position to support the miter gauge guide bar for jig or fixture mode.

Storage

How to Fold Outfeed Rollers

The recommended procedure for folding the Outfeed Rollers is to release the locking mechanism with your foot while holding the roller section firmly with two hands. (See Figure 14) Make sure there are no workpieces or anything else on the Outfeed Rollers when folding to the down position. After the locking mechanism is released, gently fold the Outfeed Rollers down as in Figure 15.

WARNING: Keep hands and body parts away from pinch points when folding Outfeed Rollers to down position.

Care and Maintenance

While the HTC Outfeed Roller is designed and built to withstand the everyday activities of virtually any workshop environment, a few common sense care and maintenance procedures can help increase the life and enjoyment of your new purchase. Keeping threaded and hinged parts free from dust buildup will keep those parts moving as freely as they are intended. Dust buildup should also be avoided on the axles of the ball bearing rollers by regular cleaning. A light lubrication (when needed) of the roller axles and Outfeed Roller hinge in the support arm action is also suggested for consistent, easy operation. A damp rag is recommended for cleaning the frame and support arm of your Outfeed Roller.

NOTE: **DO NOT** hose your Outfeed Roller down with water to clean it.

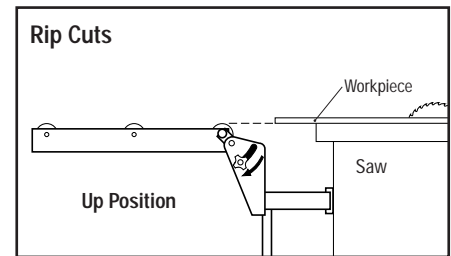

Figure 12

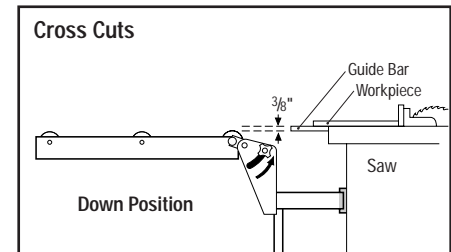

Figure 13



Figure 14



Figure 15

LIMITED LIFETIME WARRANTY

Products manufactured by HTC Products, Inc. are guaranteed to be free from defects in material and workmanship under normal use and service. HTC's obligation under this warranty shall be limited to repairing or replacing for the original owner, at our option, any part of said equipment which HTC's examination shall disclose to its satisfaction to be defective.

Any said product or component claimed to be defective is to be sent prepaid to: HTC Products, Inc., 332 E. Lincoln Ave., Royal Oak, MI 48067 Attn: Warranty Department, together with a copy of the original, dated sales receipt. Call for authorization number before shipping.

This warranty does not apply to damages resulting from shipping, accident, misuse, abuse or alteration.

Wear items (i.e. wheels, bearings, bushings, rubber feet, etc.) are warranted for a period of one year, from date of purchase. Consumable items (i.e. fence faces, saw guard shields, etc.) are warranted for a period of 60 days.



HTC Products, Inc.
332 E. Lincoln
Royal Oak, MI 48067
800-624-2027
www.htcproductsinc.com