



PM5090 Standard Pedestal Roller



OPERATORS MANUAL

Assembly • Operation • Parts List • Warnings • Warranty

Caution: Read all instructions carefully.

SAVE THESE INSTRUCTIONS.

Refer to them often and use them to instruct others.

Date Purchased: _____

Where Purchased: _____

Address: _____

Congratulations

You have just purchased a PM5090 Pedestal Roller. This product was specifically designed for use as a work support allowing safer, more convenient material handling while operating jointers, planers, bandsaws and other machines.

Safety Rules

Using power tools of any kind can be dangerous if safe operating procedures are not followed. Recognizing the hazards of each tool and using them with respect and caution will considerably limit the possibility of personal injury. However, if safety precautions are ignored, personal injury will likely result. Always use common sense – your personal safety is your responsibility.

General Safety Instructions for Power Tools

1. Know your power tool. Read and understand the owner's manual and observe the warnings and instruction labels affixed to the tool.
2. Properly ground all tools.
3. Keep guards in place.
4. Remove adjusting keys and wrenches.
5. Keep work area clean and dry.
6. Keep children away.
7. Never leave running machines/tools unattended.
8. Disconnect tools to service.
9. Regularly maintain tools.
10. Use correct tools for the job.
11. Never force a tool.
12. Wear safe apparel
13. Use safety glasses/goggles.
14. Never stand or sit on tools.
15. Replace damaged components immediately.

Assembly Instructions

Tools needed: (2) 7/16" wrenches and a putty knife.

1. Unpack and make certain all parts and hardware are included and are not damaged from shipment.
2. Install rubber tips onto the ends of the T-Leg and support leg. Start the tip onto the tube by rotating in a circular fashion. Once started, tap the tube and tip against the floor to complete installation.
3. Attach Support Leg (D) to the T-Leg (C) using 1/4" - 20 x 1 1/2" hex bolt and self-locking nut.
4. Insert Roller T (B) into the T-Leg (C) and secure with 5/16"-18 Point Knob (F).
5. Install Roller (A) into Roller Tee (B) by first inserting the fixed (non-spring loaded) end of the axle into one hole of the Roller Tee (B). Then using a putty knife like a shoe horn, slide the other end of the roller into position — the axle will snap into place.

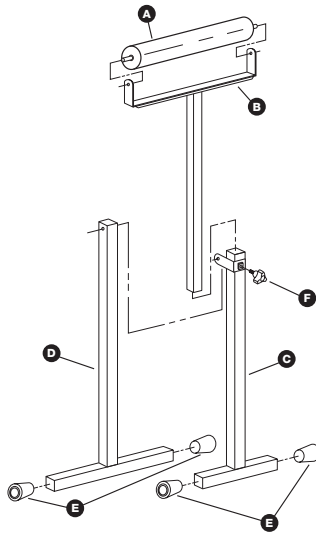

Model Number	PM5090	QTY	
A	Roller, 13" (2" Dia.)	2713	1
B	Roller Tee	2853A	1
C	T-Leg – Main	2853B	1
D	Support Leg	2854	1
E	Rubber Tip	A-302	4
F	5/16"-18 Point Knob	G101	1
	1/4"-20 x 1 1/2" Hex Bolts	D-132	1
	1/4"-20 Self-locking Nut	D-102	1

One Year Limited Warranty

Warrantor warrants to the original purchaser that the PortaMate PM5090 will be free from defects in materials and workmanship under normal use and service for a period of one (1) year from the date of original purchase.

The obligation of this Warranty is limited to repair or replacement, at our option, of components which prove defective under normal use.

Any product or component claimed to be defective should be sent during Warranty period, postage prepaid to **PortaMate, 332 E. Lincoln, Royal Oak, MI 48067, Attn: Warranty Department**, together with a copy of your original dated sales receipt. Call for authorization number before sending.

This warranty is in lieu of all other express warranties, obligations or liabilities. ANY IMPLIED WARRANTIES, OBLIGATIONS OR LIABILITIES, SHALL BE LIMITED IN DURATION TO THE ONE YEAR PERIOD OF THIS LIMITED WARRANTY. NO AGENT, REPRESENTATIVE, DEALER, OR EMPLOYEE OF THE COMPANY HAS THE AUTHORITY TO INCREASE OR ALTER THE OBLIGATIONS OF THIS WARRANTY.

This Warranty shall not apply to any product or component which in the opinion of the Warrantor has been modified or altered in any way, damaged as a result of an accident, misuse or abuse, or loss of parts. In no case shall the Warrantor be liable for any special or consequential damages, or any other costs or warranty, expressed or implied, whatsoever.

This Warranty gives you specific legal rights, and you may also have other rights which vary from state to state.

Your satisfaction is very important to us.
Please return your warranty card
with comments or suggestions.

Customer Service Department
248-399-6185 or **800-624-2027**